

# Brio Weatherfold 4s 150

INSTBWSH1 REV D - MAY 2015

Brio Australia  
 P: +61 2 87186718  
 W: [brio.com.au](http://brio.com.au)  
 E: sales@brio.com.au

Brio UK  
 P: +44 191 2291224  
 W: [briouk.com](http://briouk.com)  
 E: sales@briouk.com

Brio USA  
 P: +1 585 3195599  
 W: [briousa.com](http://briousa.com)  
 E: sales@briousa.com

## Codes

**B WS 1 - 150 S H PR** ——— Finish: PR (Physical Vapour Deposition Black), SS (Satin Stainless)  
 Hinge Type: See section Hinge Installation (page 5)  
 Bearing Type: S (Stainless Steel Bearing)  
 Load Capacity: 150kg (330lbs)  
 Set No.: 1 (Pivot Set), 2 (End Hanger Set), 4 (Intermediate Hanger Set),  
 3 (Hinge Handle Set), 5 (Hinge Set), 6 (Offset Hinge Set),  
 7 (Offset Hinge Handle Set)

Brio Weatherfold 4s

## Sets note codes do not show finish, hinge sets not shown to same scale

BWS1-150H

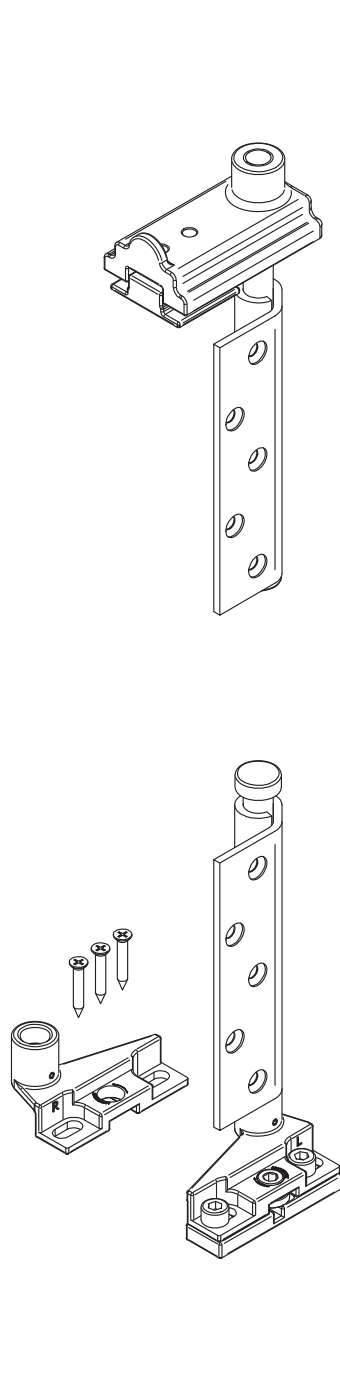

BWS4-150SH

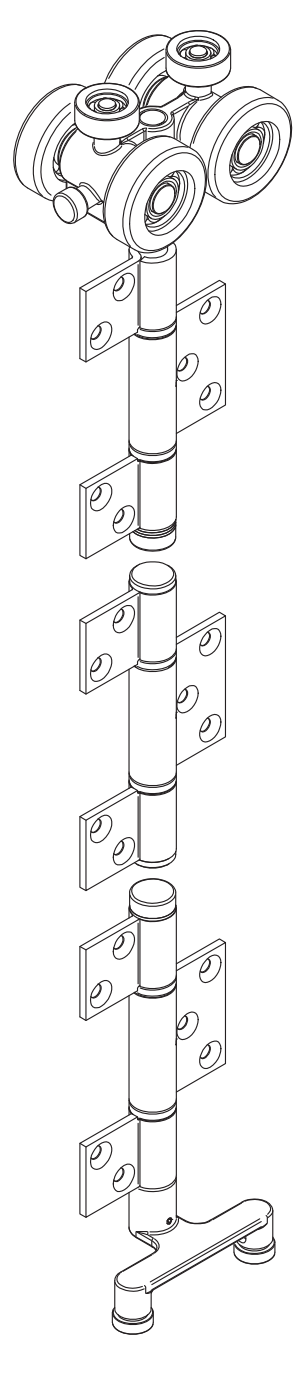

BWS2-150SH

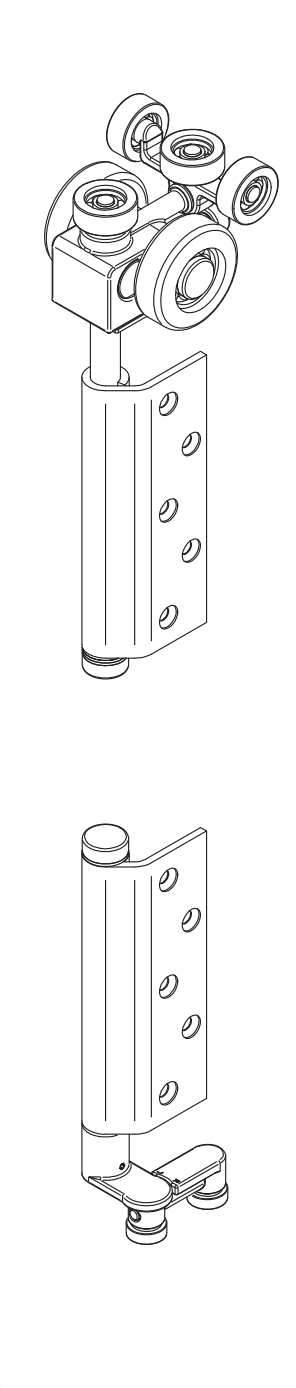

BW3-150H

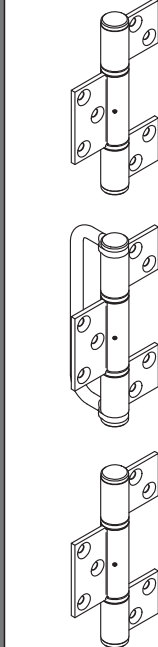

BW5-150H

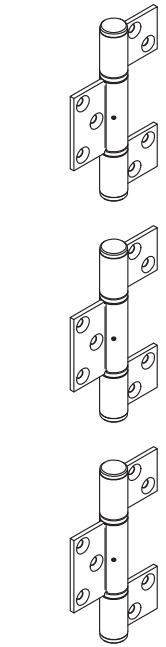

BW6-150H

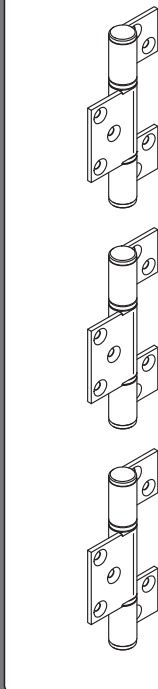

BW7-150H

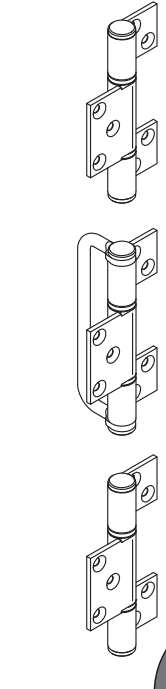

# Door Hardware Set Orientation

FB = Flush Bolt, FP = Flush Pull, LK = Lock, left systems shown

## OUTWARD OPENING

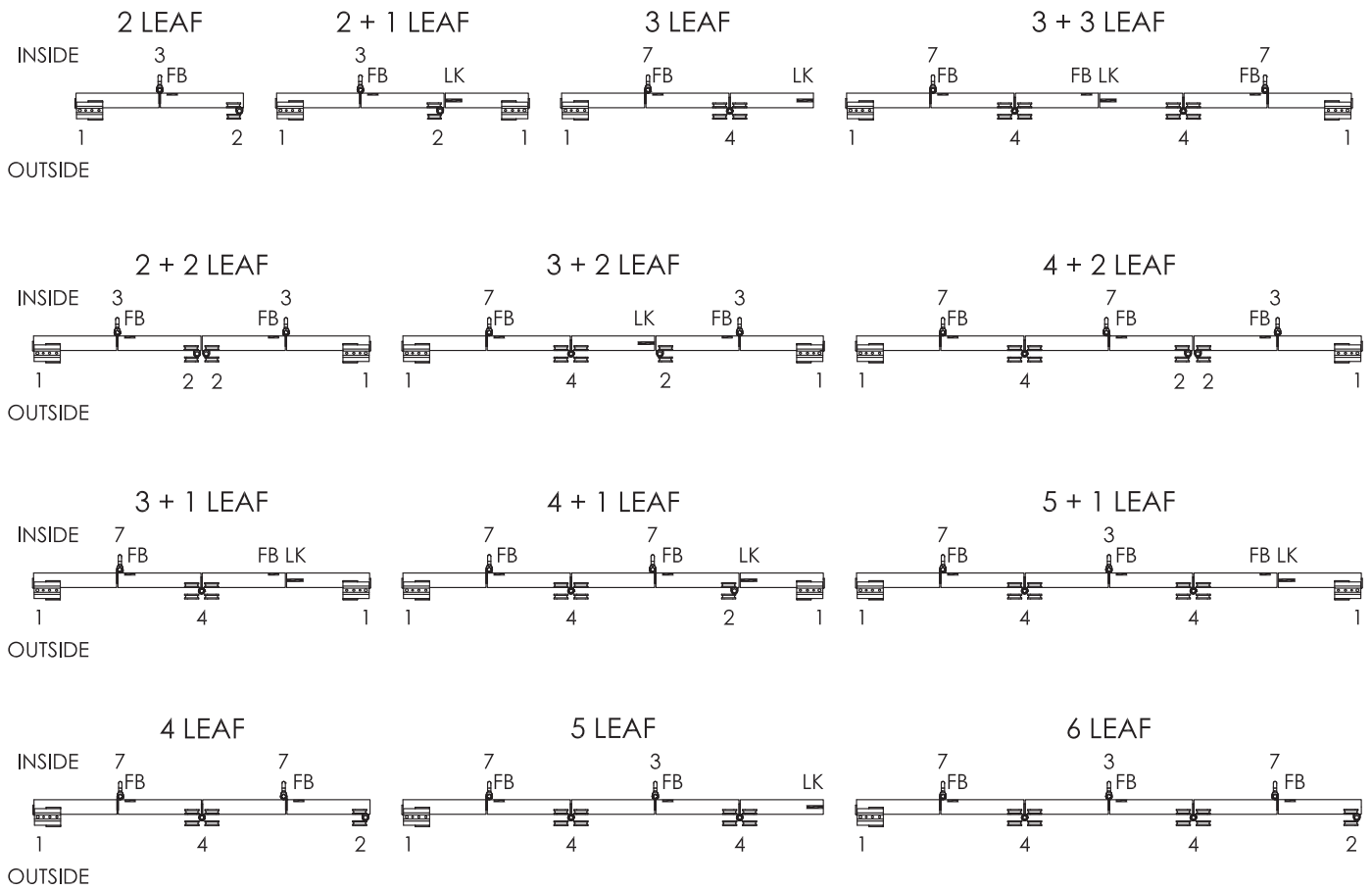

## INWARD OPENING

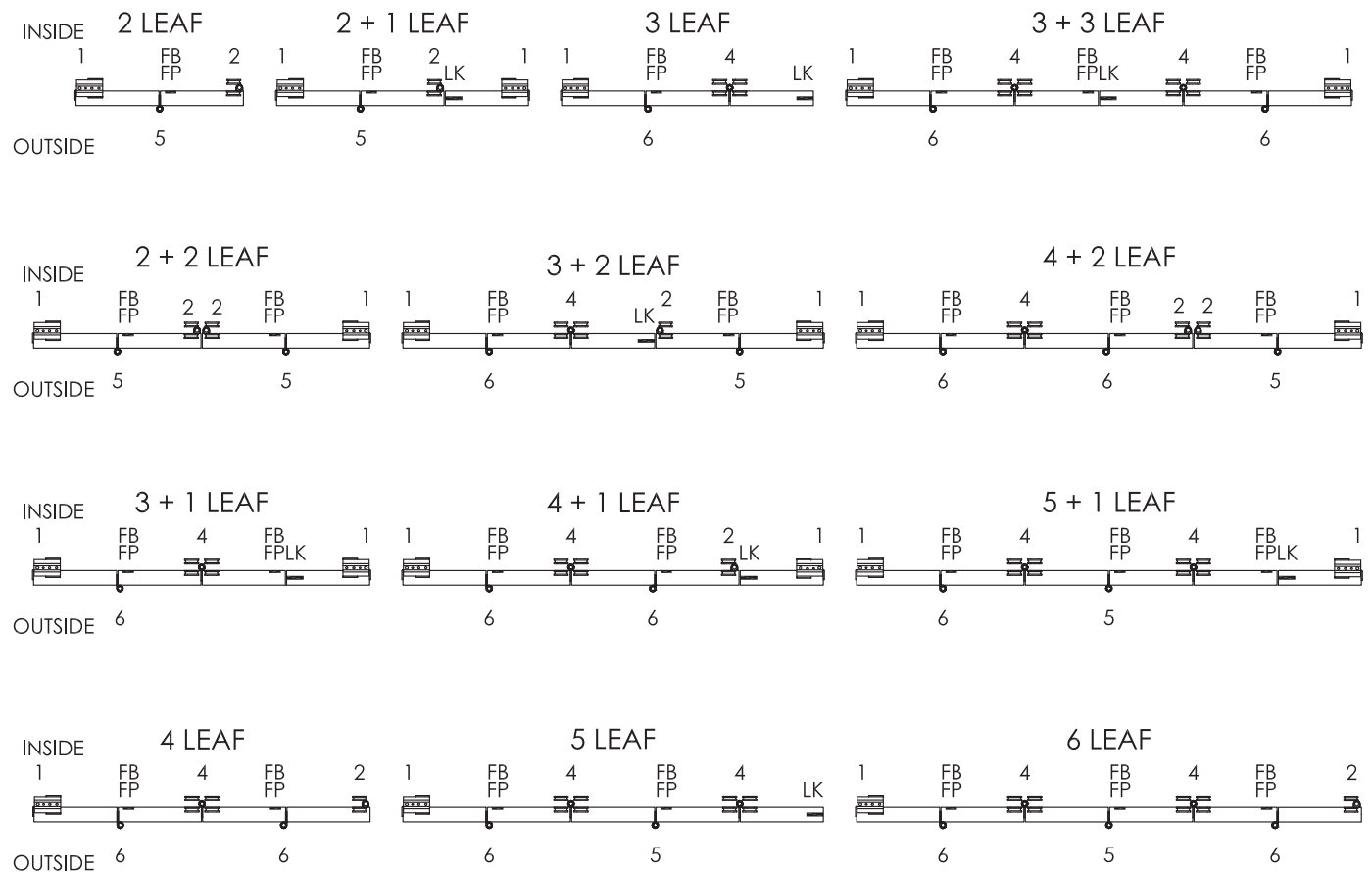

# Opening Preparation note outward opening, dimensions shown in mm[inches]

TRACK AND HEADBOARD TO BE FIXED TO LOAD BEARING STRUCTURE (STEEL BEAM)  
CONSULT A STRUCTURAL ENGINEER

Timber headboard can be replaced with timber packers or gasket material

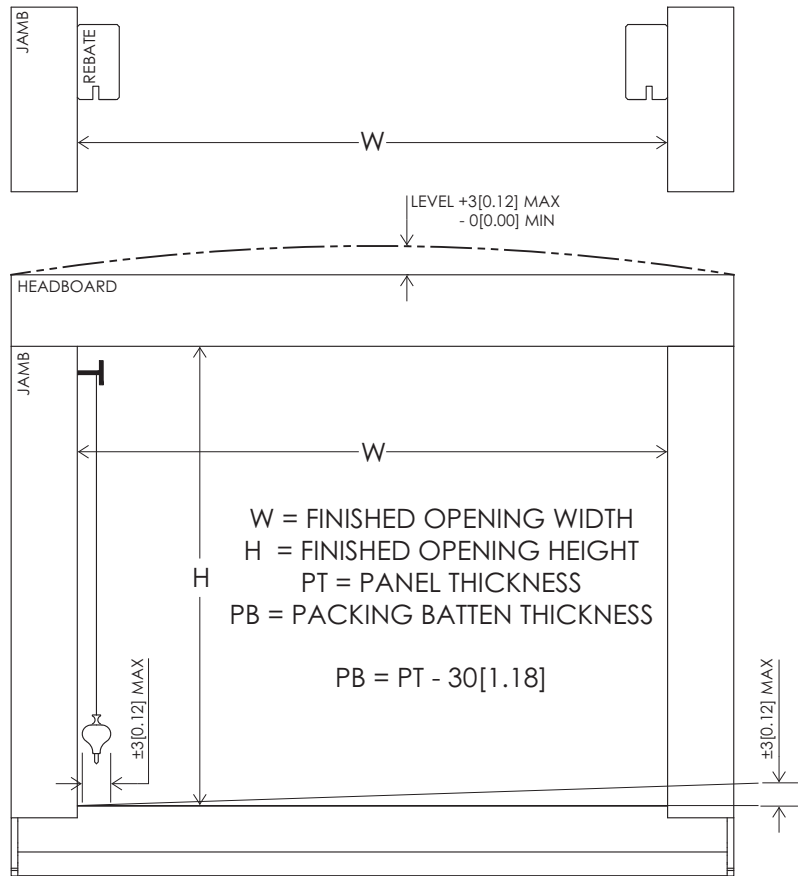
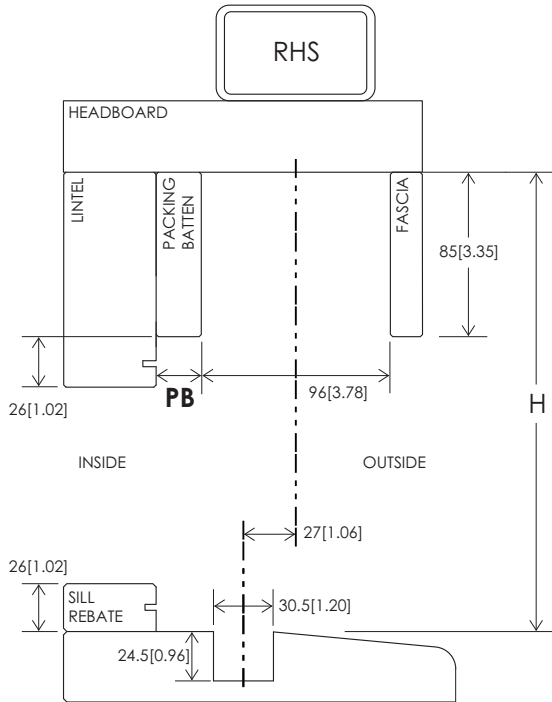

## Track & Channel Preparation track & channel cut to length 'W' (finished opening width)

Countersink channel 20[0.79] from ends and at 400[15.75] intervals

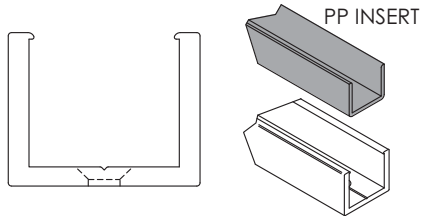

PP Insert =  $W - 95[3.74]$ , insert from non-pivot end after pivot installed

Cut track to allow access to hangers by removing track section

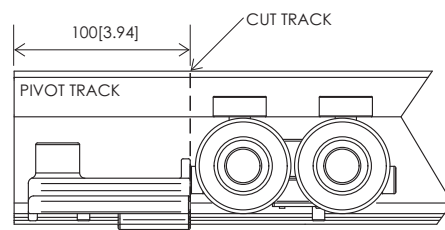

Install pivot track once hangers in

Use rods 700TJR for all other joints

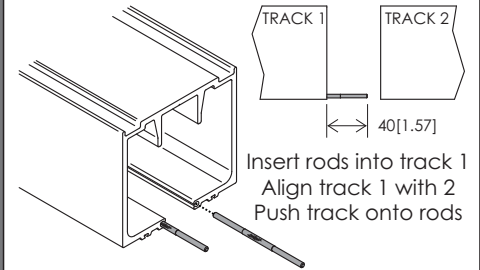

Assemble sections before installing

## Install Track & Channel

Insert Polypile

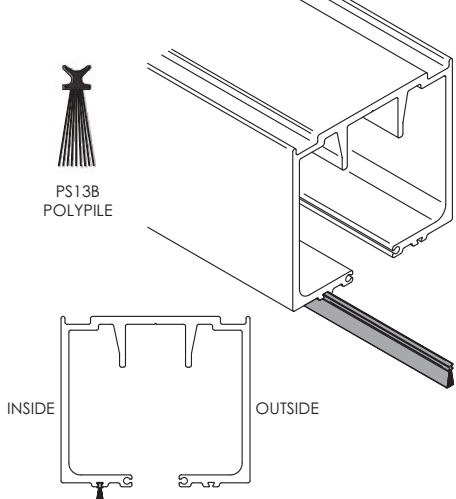

Install polypile on inside of system

Fix track with 12G Roofing Screw by 100[4.00] through to RHS

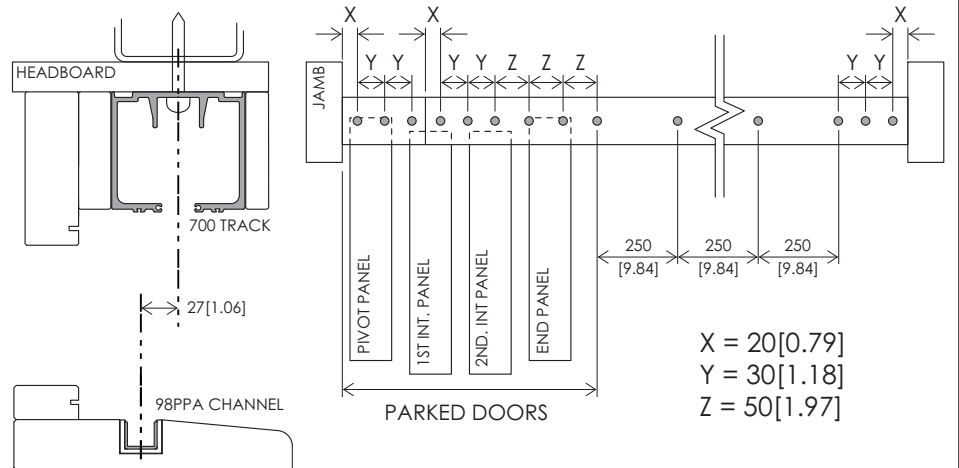

After initial end of track fixings (X & Y) fix track at 50[1.97] intervals (Z) above all parked doors, then fix track at 250[9.84] intervals

# Panel Size Calculation

Brio Weatherfold 4s allows for equal size panels

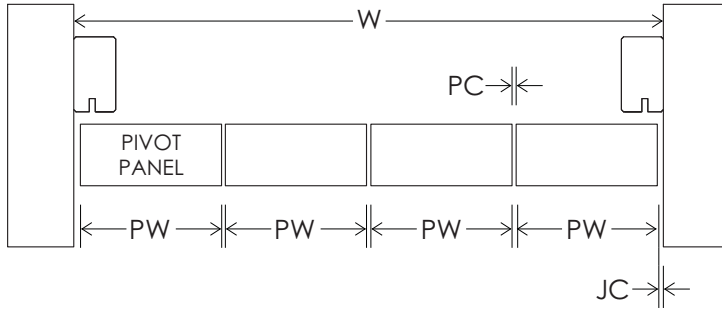

N = No. of Panels  
 PW = Panel Width  
 JC = Jamb Clearance = 8[0.32]  
 PC = Panel Clearance = 4[0.16]

$$PW = \frac{W - [PC(N-1) + 2(JC)]}{N}$$

JC based on panels 1000[39.37] wide and 57[2.25] thick

PH = Panel Height

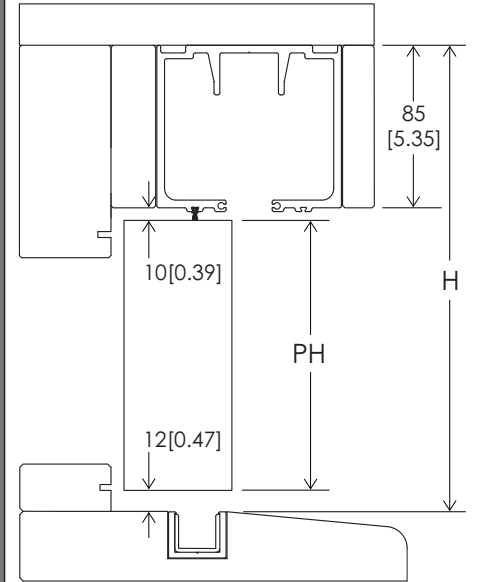

$$PH = H - 107[4.21]$$

## Seal Preparation note left opening system shown

Frame - AQ21 perimeter seals to butt against each other in all corners

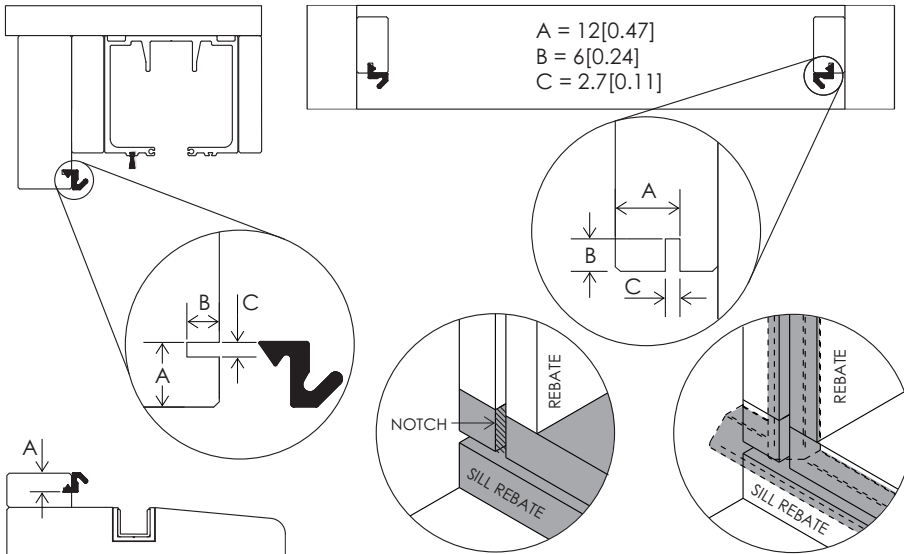

Lintel and sill rebate to be notched as shown

Panel - AQ33

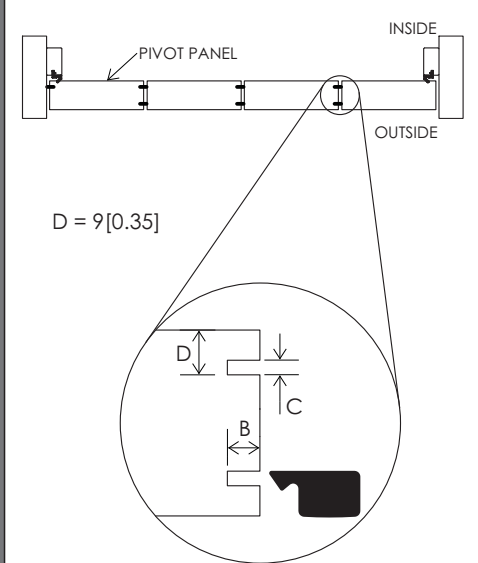

## Meeting Door Selection

2 Meeting end panels

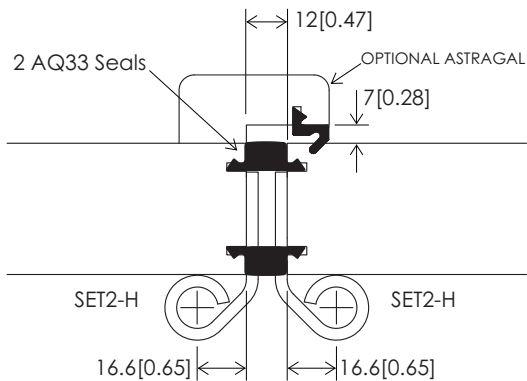

End panel meeting swing door

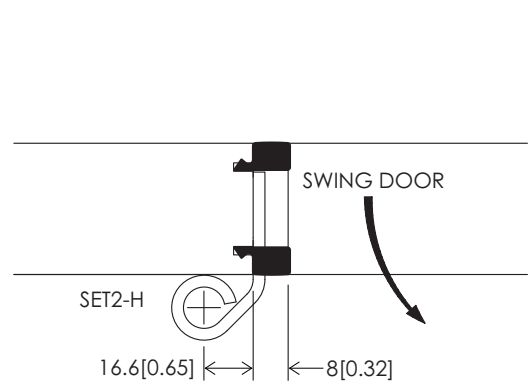

# Hinge Installation Pilot hole of $\varnothing 3.5\text{mm}$ [0.14"] recommended

Non-mortice H  
44[1.73]-68[2.68] Panel Thickness

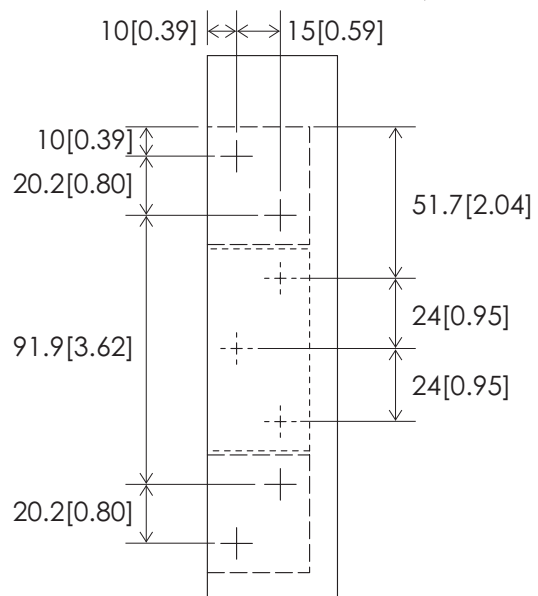
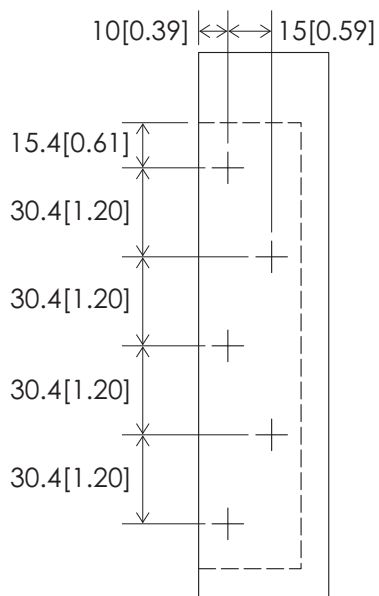
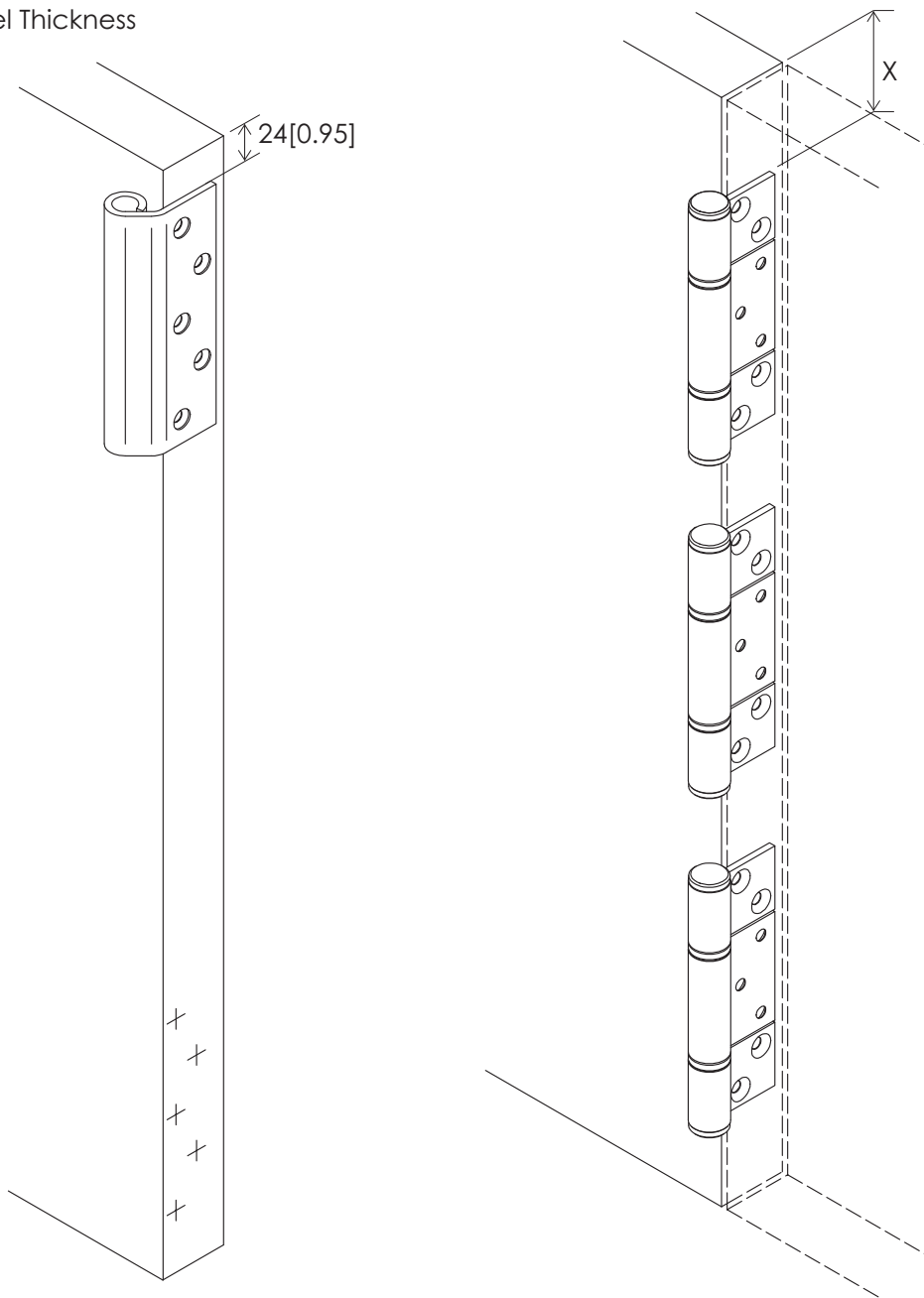

X=24[0.95] on Set 4  
X=60[2.36] min on Sets 3, 5, 6 & 7

# End Guide

when viewed from outside doors folding left need a left end guide and vice versa for right

## Handing End Guide

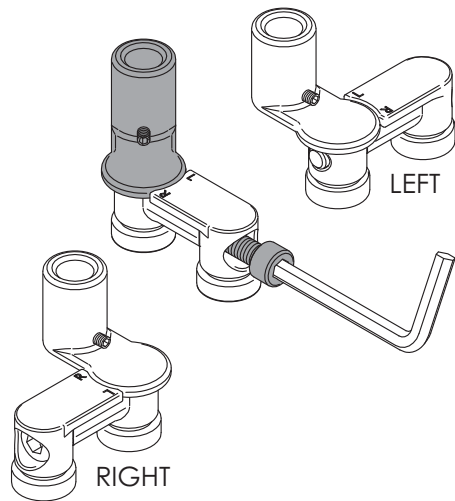

Back off cap screw and rotate guide arm into left or right position

## Determining System Orientation

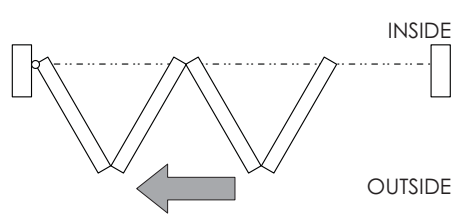

Left, outward opening system

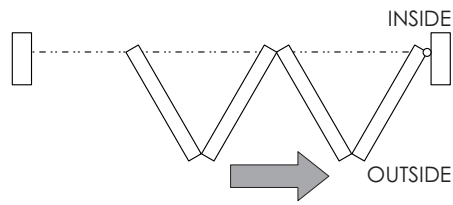

Right, outward opening system

## Handing end set hinge

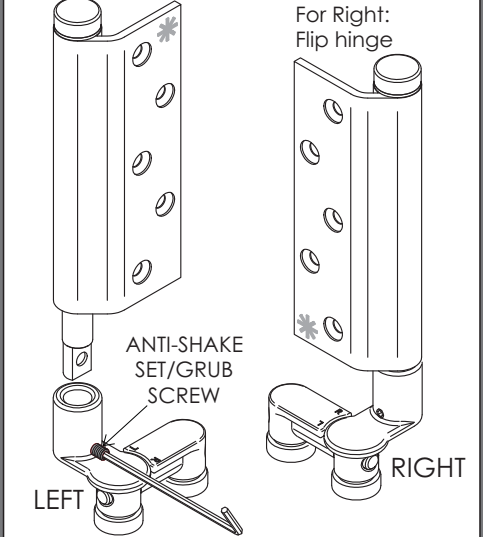

Lock off anti-shake set/grub screw

# Bottom Pivot

when viewed from outside doors folding left need a left pivot and vice versa for right

## Handing Bottom Pivot

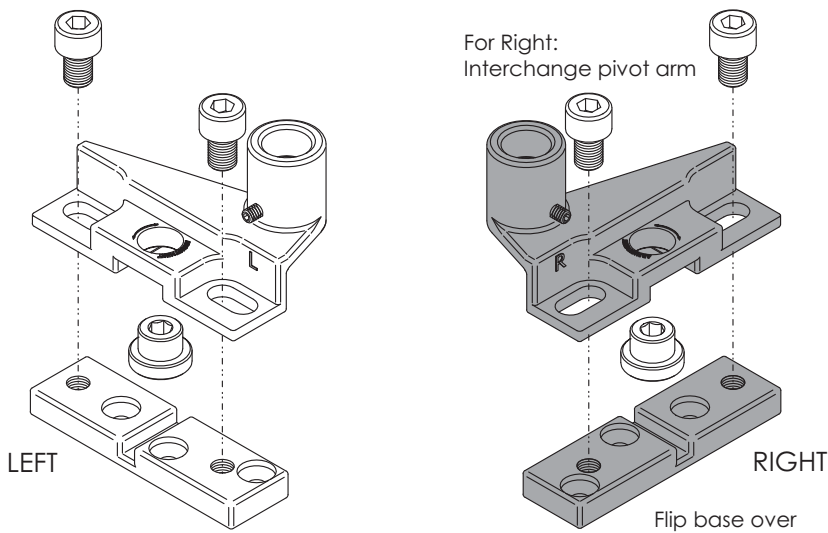

Secure assembly by locking off cap screws

## Handing pivot set hinge

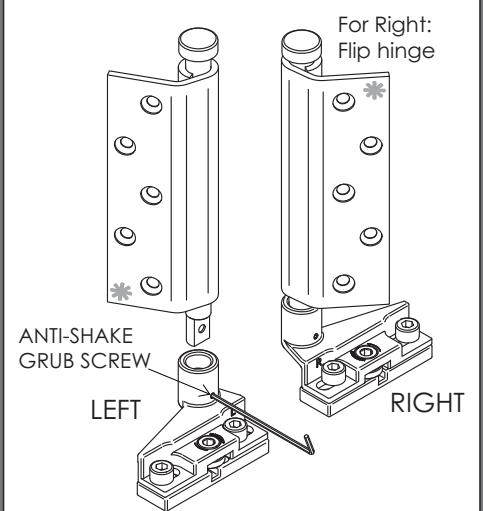

Lock off anti-shake set/grub screw

# Intermediate Set

security set/grub screw application

## Hanger security

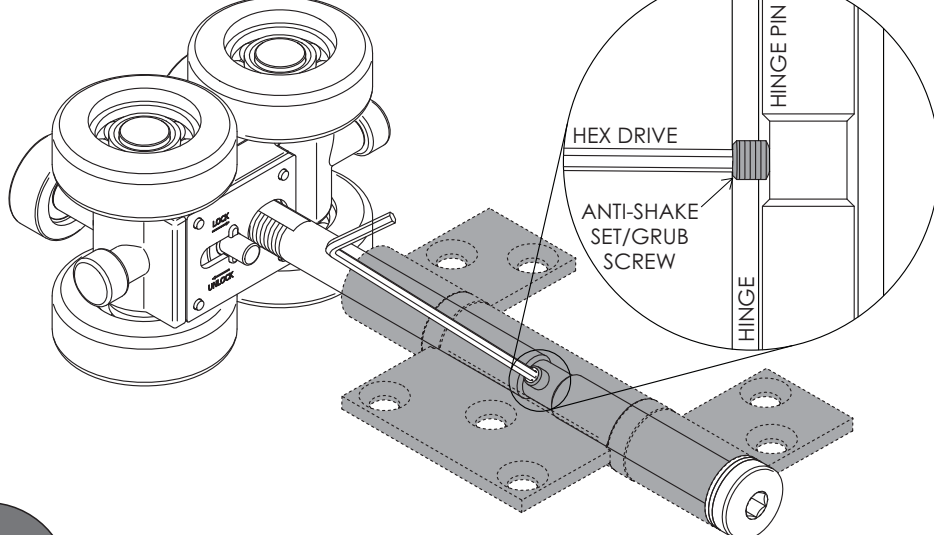

Anti-shake set/grub screw prevents pin being removed from hinge

## Guide security

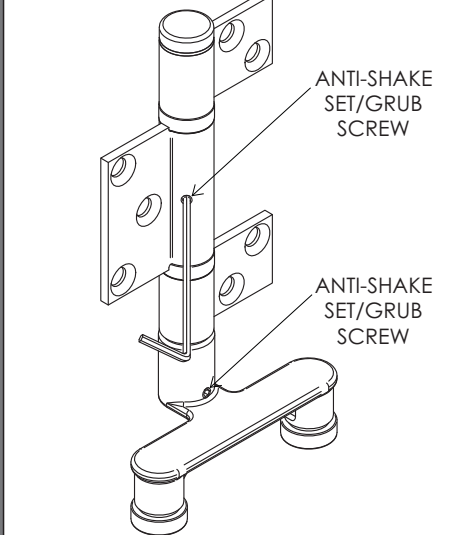

Lock off both set/grub screw

# Optional Extras jamb pivot and flush bolts, see page 2 for flush bolt location on all configurations

### Installation of jamb pivot

Hinge aligns with other centre hinges

Wind jamb pivot bolt in or out until it aligns with hinge pin

FLUSH BOLT	X
456R	190[7.48]
456RL	450[17.72]
456RLX-600	600[23.62]
456RLX-1000	1000[39.37]

X = PT + 17[0.67] Assemble after top and bottom pivot are set

### Install flush bolt to panel

For square flush bolts chisel out corners

Counter bore for lockable flush bolts

Router available for flush bolt

### Install keeper to sill

Mark where flush bolt throw strikes sill and notch out hollow for dust box

## Attaching Hardware to Panels recommended before installation

Ensure doors are level and square from top

Set 1, Set 2, Set 4, Set 7

PIVOT PANEL  
1ST INT. PANEL  
2ND INT. PANEL  
END PANEL

## Installing Hardware and Hanging Panels clean down inside of track and channel

### Viewed from outside, insert rollers through opening in correct order

Once all hangers in, attach pivot track section

### Lock top pivot into position

CLAMP PLATE  
CAP SCREWS

### Place bottom pivot base in channel

98 Channel  
98 PP Insert cut 95[3.74] short of 98 Channel

Screw fix base in place

### Assemble pivot

ARM & HINGE  
CAP SCREWS  
CAM

### When cap screws loose, pivot arm can slide freely

Securely assemble bottom pivot for installation

# Hanging Panels

Bring pivot panel to pivot set

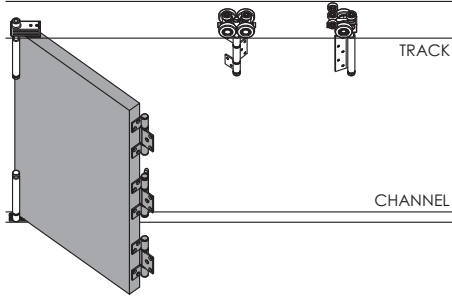

Hinge set 7 attached to pivot panel

Bring 1st int. panel to pivot panel

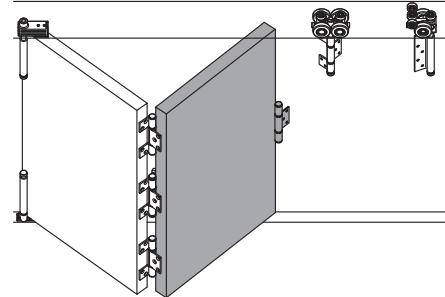

Middle hinge of int. set attached

Fix int. hanger to int. panel

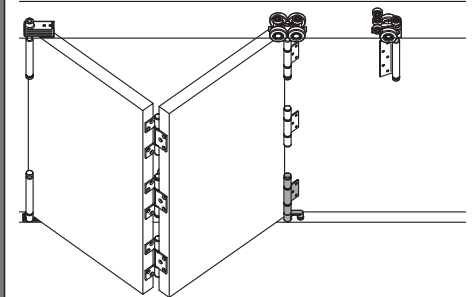

Attach int. guide to int. panel

Bring 2nd int. panel to the int. hanger with hinge set 7

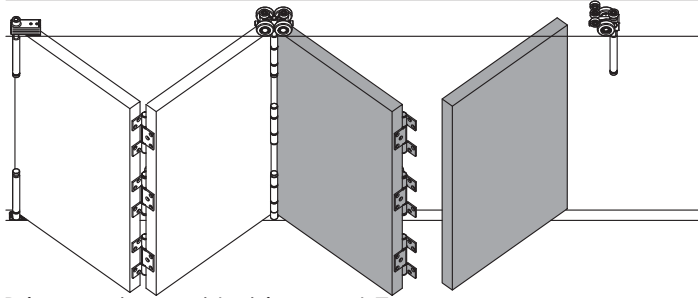

Bring end panel to hinge set 7

Fix end panel to end hanger

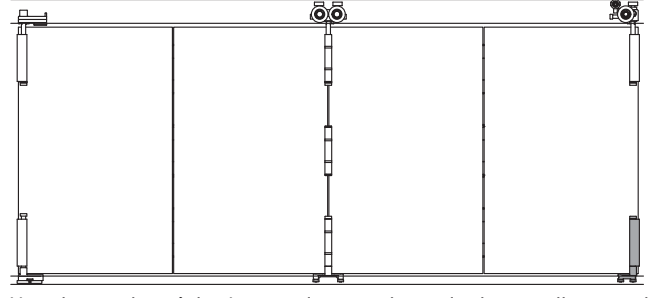

Attach end guide to end panel and close all panels

## Adjustment bolt locking mechanism applied to all hangers and top pivot

Push in spring loaded button

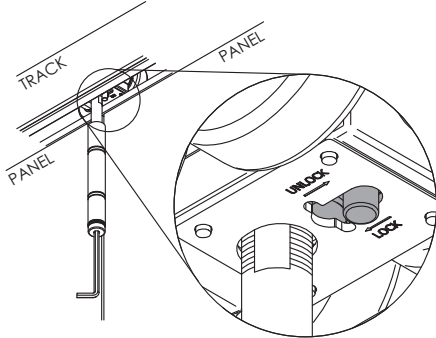

Slide back spring loaded button & collar before winding bolt in or out

Adjust all hangers and top pivot until panels are level with track

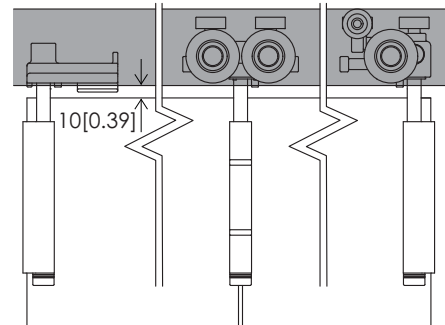

Once panels are level, partially open doors - lock off 1st cap screw

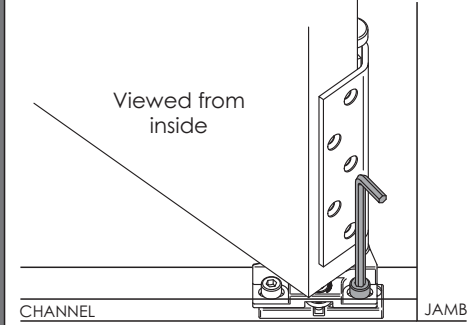

Open fully, lock off 2nd cap screw

## System Overview

